

DAVIT SYSTEMS

Davit Systems are a traditional and effective method to provide permanent access to exterior building facades

The basic system is comprised of:

- fixed davit bases,
- portable davit arms (mast & boom assemblies)
- powered work platform
- dual-line suspension system
- horizontal life-lines

Other davit system equipment available:

- TIRFOR manual davit lifting hoists
- davit arm lifting brackets
- davit boom turning handles
- material lifting hoists

Special conditions can incorporate:

- portable davit bases
- flush mounted pedestals

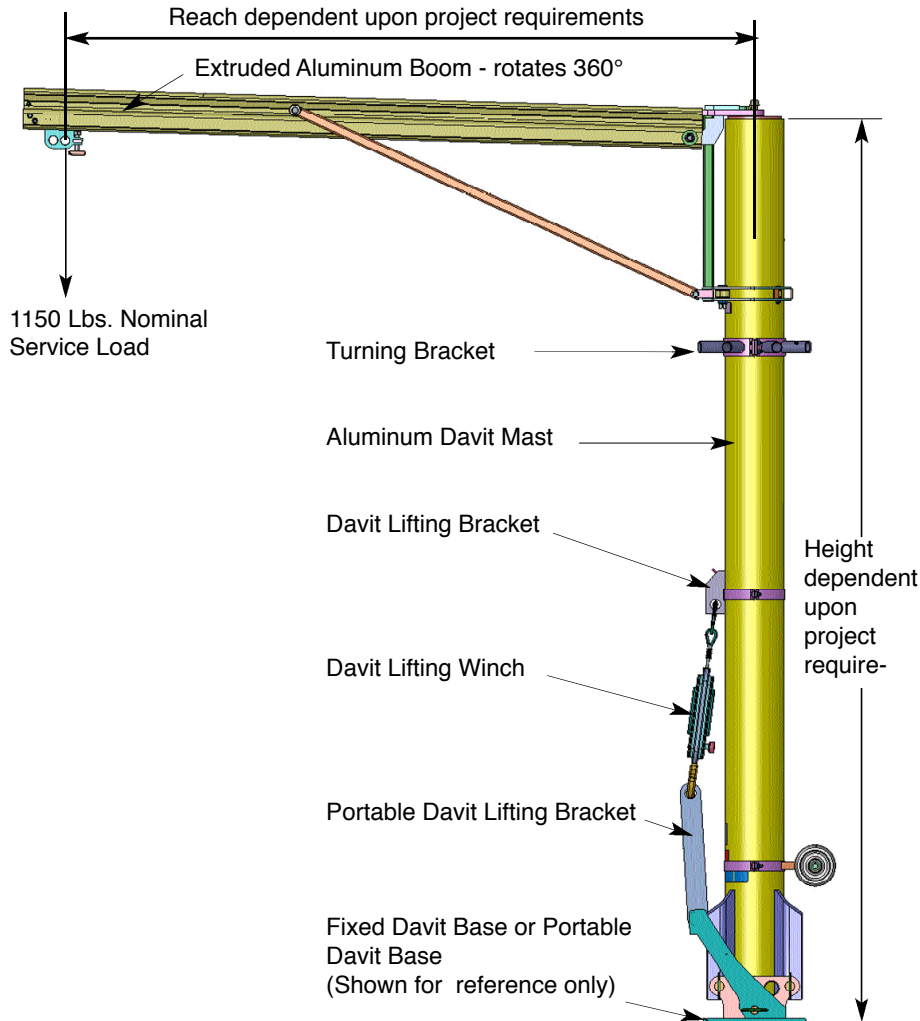

Standard Connections

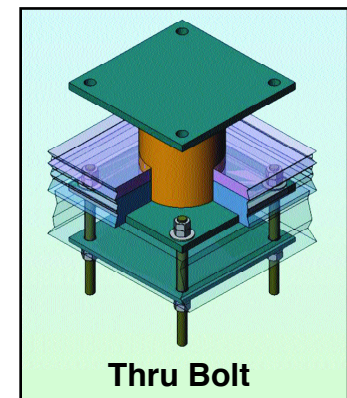
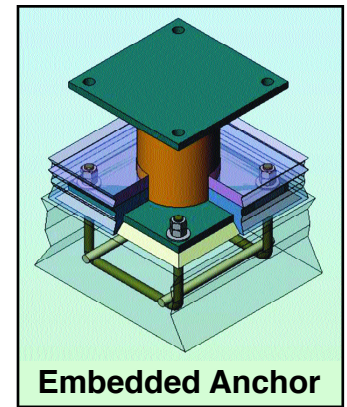
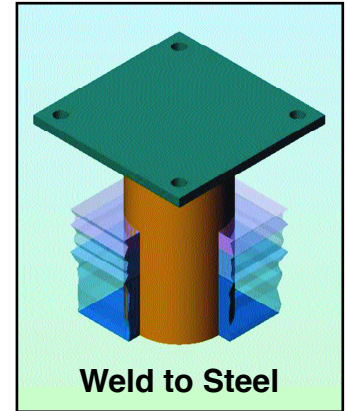

davit bases

Of the various types of *Davit Systems* available, those incorporating fixed **davit bases** are the best solution for long-term value.

The machined tolerances of Tractel's davit bases ensure the davit mast fits securely and quickly, with no extra parts to adjust. For this reason, fixed bases are components of the most labor-efficient davit system.

Fixed models can be mounted directly to the roof structure with cast-in anchors, as shown in fig. 1, below.

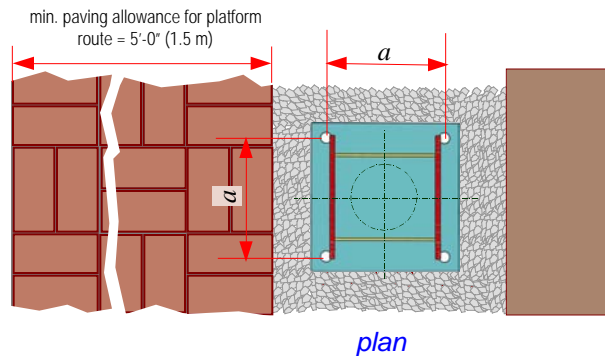
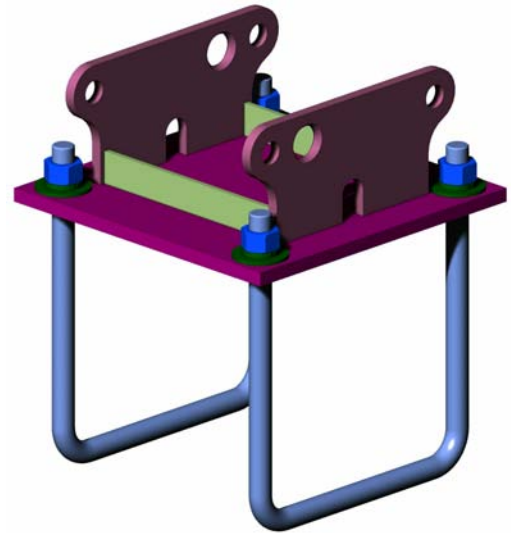

DAVIT BASE – series DS
bolted to cast-in-place anchor bolts

materials:

base
G40.21-44W galvanized steel $F_y = 44 \text{ KSI}$

anchor bolt cage
A307 zinc plated steel

hex nuts, washers:
A307 zinc plated or A325 galvanized steel

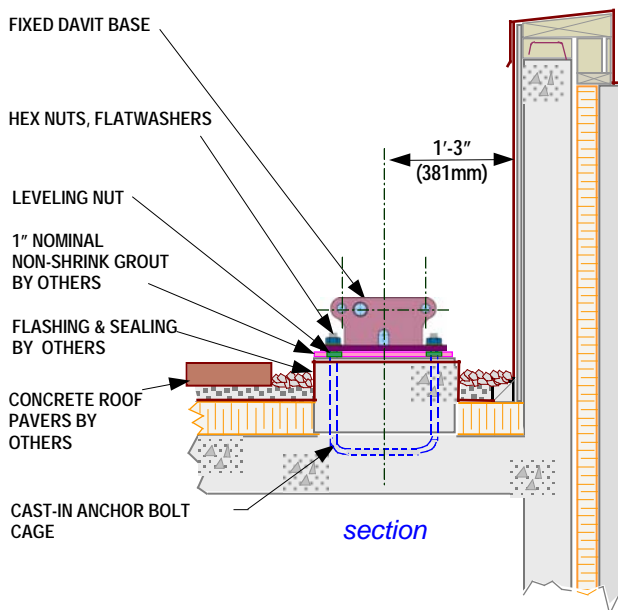

ref. no.	maximum davit boom reach	a	weight
DS5	8'-6" (2.59 m)	12" (305 mm)	70 lbs (32 kg)
DS8	12'-6" (3.81 m)	13" (330 mm)	90 lbs (41 kg)

fig. 1

davit bases (continued)

Of the various types of *Davit Systems* available, those incorporating fixed **davit bases** mounted to **pedestals** supplied during construction are an efficient solution for long-term value.

Support pedestals can be supplied and welded to the structure during construction. Tractel can provide shop drawings indicating locations and structural requirements for the pedestals, as well as bolt hole locations for the sockets. Alternatively, this connection can be welded or clamped to these supports.

The machined tolerances of the bases ensure the davit mast fits securely and quickly, with no extra parts to adjust. For this reason, *fixed davit bases* are components of the most labor-efficient davit system.

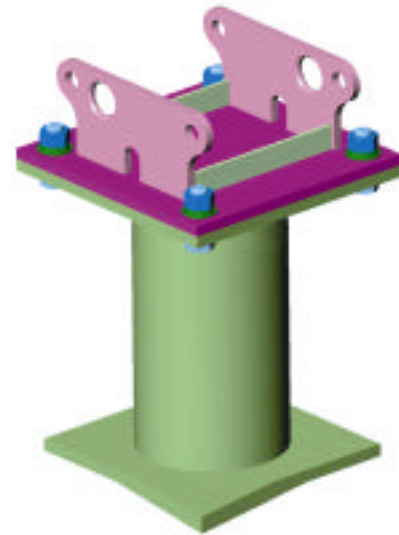

DAVIT BASE series DS

bolted to pedestal

materials:

base

G40.21-44W galvanized steel $F_y = 44$ KSI

anchor bolts

A307 zinc plated steel

hex bolts, nuts, washers:

A307 zinc plated or A325 galvanized steel

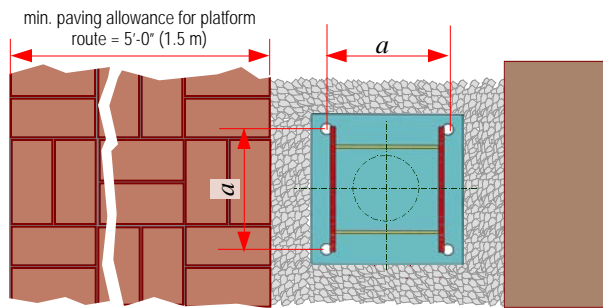

plan

DAVIT PEDESTALS series DPB

clamped to concrete

materials:

pedestal, clamp angle

G40.21-44W galvanized steel $F_y = 44$ KSI

anchor rod

A307 zinc plated steel

hex nuts, washers:

A307 zinc plated or A325 galvanized steel

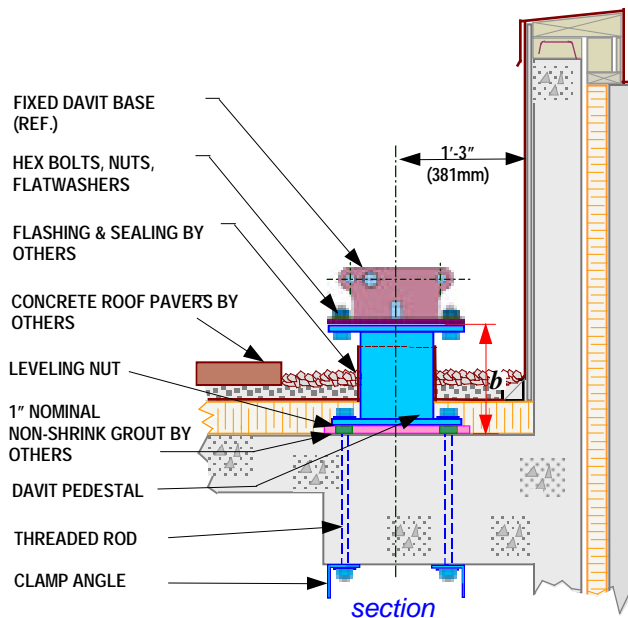

fig. 2

ref. no.	maximum davit boom reach	a	weight
DS5	8'-6" (2.59 m)	12" (305 mm)	70 lbs (32 kg)
DS8	12'-6" (3.81 m)	13" (330 mm)	90 lbs (41 kg)

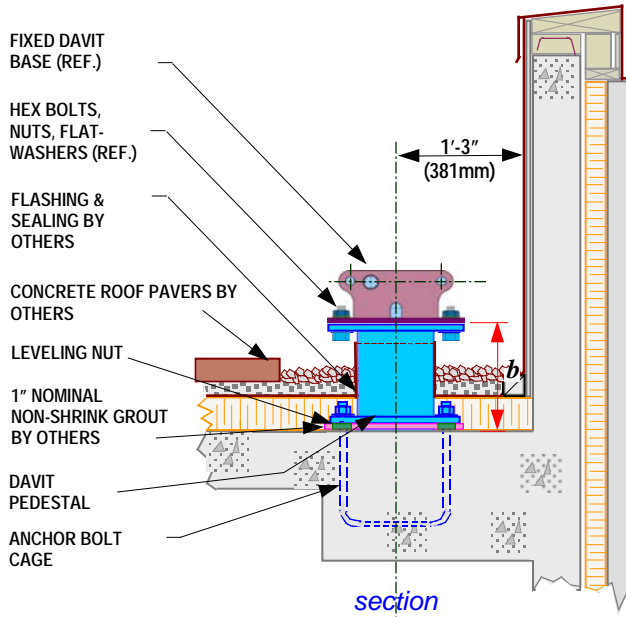

fig. 3

DAVIT PEDESTALS series DPB
bolted to cast-in-place anchor bolts

materials:

pedestal

G40.21-44W galvanized steel $F_y = 44 \text{ KSI}$

anchor bolt cage

A307 zinc plated steel

hex nuts, washers

A307 zinc plated or A325 galvanized steel

ref. no.	maximum davit boom reach	a	weight
DS5	8'-6" (2.59 m)	12" (305 mm)	70 lbs (32 kg)
DS8	12'-6" (3.81 m)	13" (330 mm)	90 lbs (41 kg)

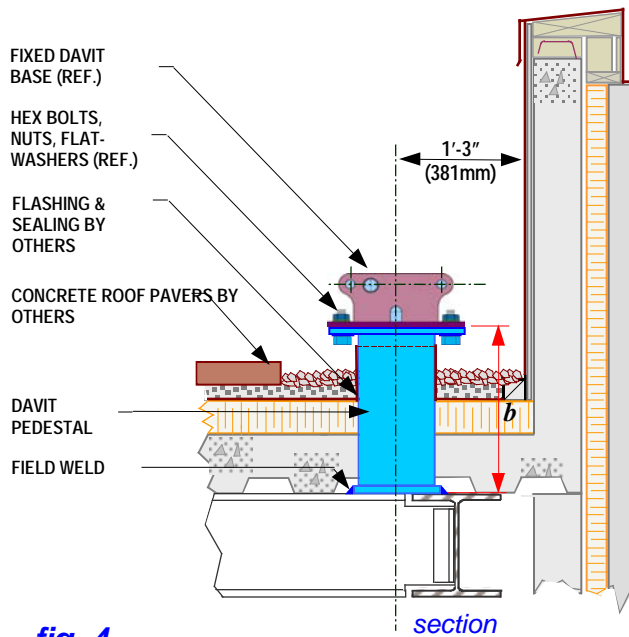

fig. 4

DAVIT PEDESTALS series DPB
welded to steel structure

materials:

pedestal

G40.21-44W galvanized steel $F_y = 44 \text{ KSI}$

ref. no.	maximum davit boom reach	a	weight
DS5	8'-6" (2.59 m)	12" (305 mm)	70 lbs (32 kg)
DS8	12'-6" (3.81 m)	13" (330 mm)	90 lbs (41 kg)

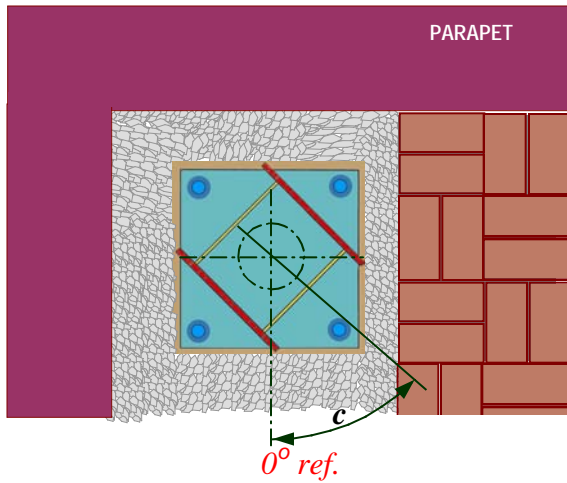

davit base angulation

Tractel davit bases are typically supplied at an angle to the parapet wall. This angulation ensures worker safety, as the davit arm erection never occurs alongside the parapet wall. Often all davit bases are supplied with the same angle to prevent incorrect location during installation.

Angled davit bases are especially required when space limitations prevent erecting the davit arm at right angles to the parapet wall.

fig. 11

TYPICAL ANGULATION – angle *c*

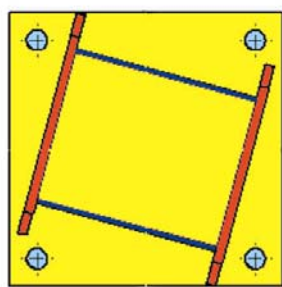

15° CW - D3

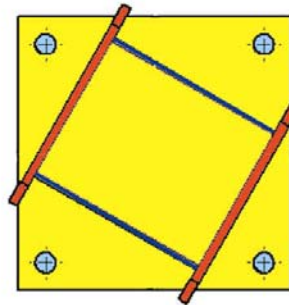

30° CW - D4

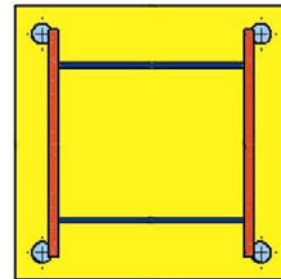

0° - 90° - D0

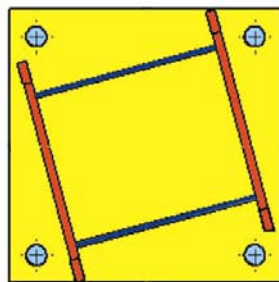

15° CCW - D8

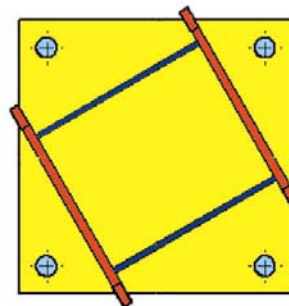

30° CCW - D9

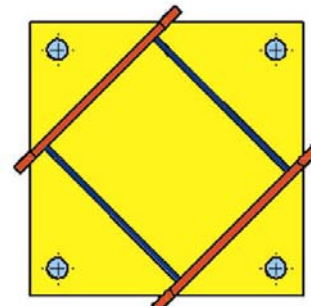

45° - D5

**flush davit base,
used as a portable davit base**

Flush davit bases, when used with fixed flush style pedestals, can provide a cost-effective approach to provide the support equipment for a davit system. These portable systems are most effective on smaller, single level applications, and are accepted by many regional codes.

A pair of portable flush davit bases slide into the fixed flush style davit pedestals and are secured with provided pins. Davit arms are then fitted to each base, and the davits are erected and secured. The flush davit bases are then moved from location to location, along with the powered platform.

All varieties of flush style pedestals are available for every mounting method, including new or retrofit applications. Fig. 2 shows a typical detail, and other attachment methods are available.

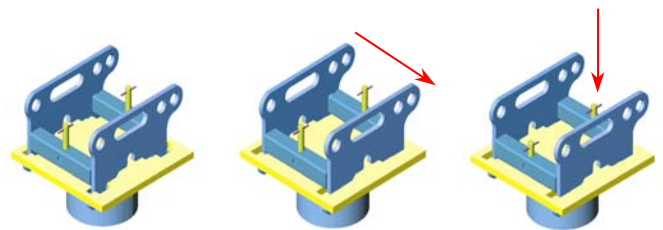
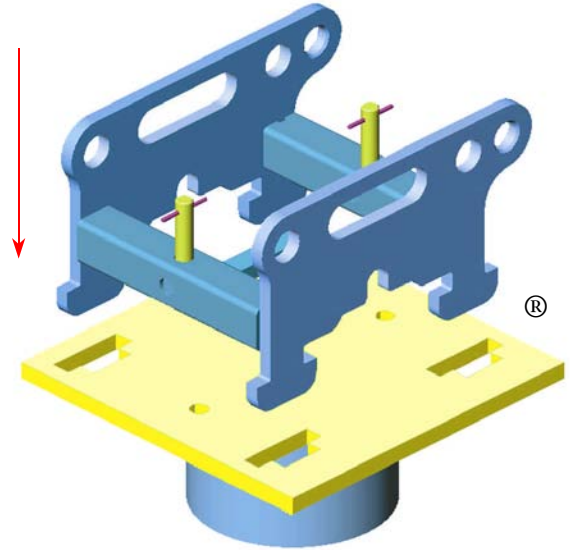

FLUSH DAVIT BASE series DS

materials:

base - G40.21-44W galvanized steel $F_y = 44 \text{ KSI}$

ref. no.	maximum davit boom reach	weight
DS5F	8' - 6" (2.59 m)	36 lbs. (16 kg)
DS8F	12' - 6" (3.81 m)	50 lbs. (23 kg)

FLUSH DAVIT PEDESTAL series DPF
welded to steel structure

materials:

pedestal - G40.21-44W galvanized steel $F_y = 44 \text{ KSI}$

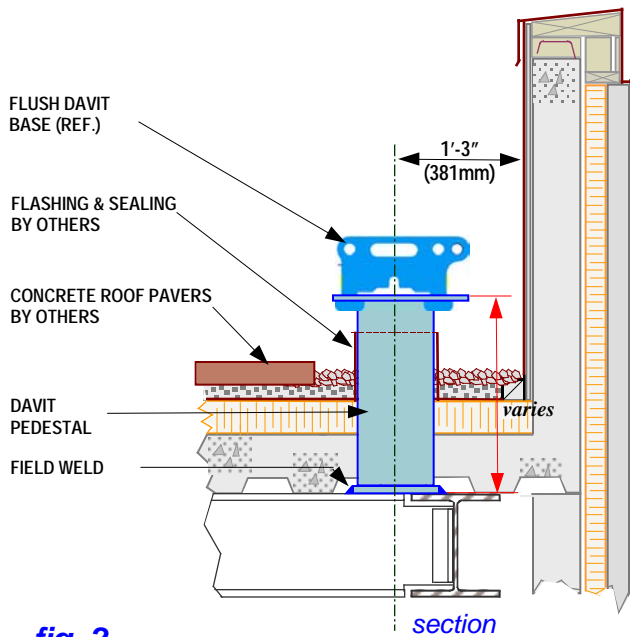

fig. 2

flush davit bases & pedestals

When davit bases are required on roofs where aesthetics, pedestrians or other traffic does not permit any protuberances, Tractel's **flush davit pedestals** provide an attractive solution.

Davit base adapters are temporarily fitted fixed to these special pedestals, secured with provided pins, making them ready to accept the davit arm.

All varieties of standard pedestals are available for every mounting method, including new or retrofit applications. Fig. 2 shows a typical detail, and other models are available.

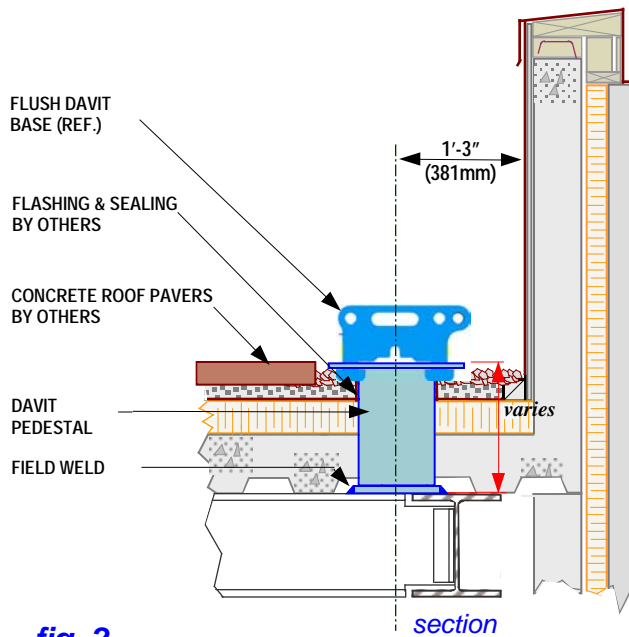
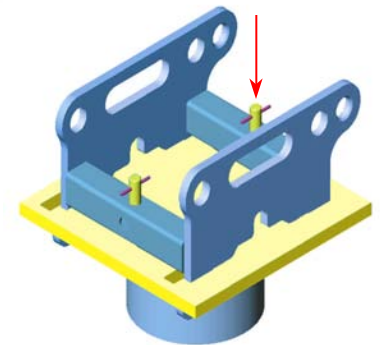
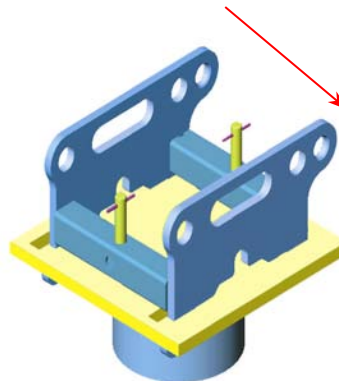
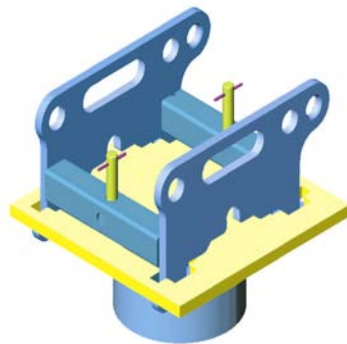
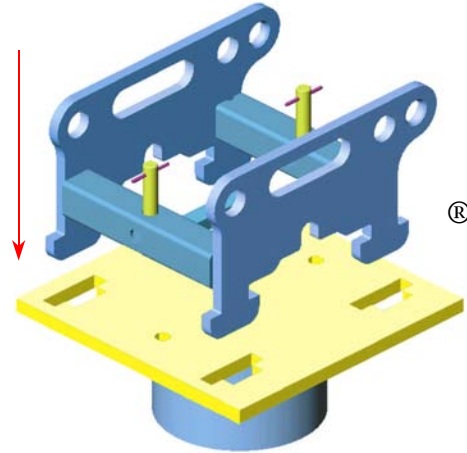

fig. 2

FLUSH DAVIT BASE series DS

materials:

base - G40.21-44W galvanized steel $F_y = 44$ KSI

ref. no.	maximum davit boom reach	weight
DS5F	8' - 6" (2.59 m)	36 lbs (16 kg)
DS8F	12' - 6" (3.81 m)	50 lbs (23 kg)

FLUSH DAVIT PEDESTAL series DPF
welded to steel structure

materials:

pedestal - G40.21-44W galvanized steel $F_y = 44$ KSI

davit masts

The davit mast separates from the boom and is transportable by means of a permanent pair of wheels at one end. Davit pivoting pins are provided for connection to the davit base. The turning bracket & handle permit easy boom rotation from inside the platform.

All standard masts have a rated capacity of 1150 lbs. or 525kg.

options:

Davit lifting bracket, manual lifting hoist, davit turning handle.

materials:

Type 6061 T-6 aluminum, G40.21-44W galvanized steel
Fy = 44 KSI, A307 zinc plated or A325 galvanized steel, rubber/urethane wheels.



TOP VIEW

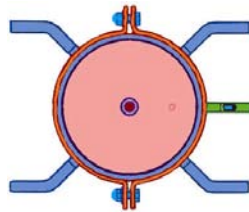

DAVIT MAST

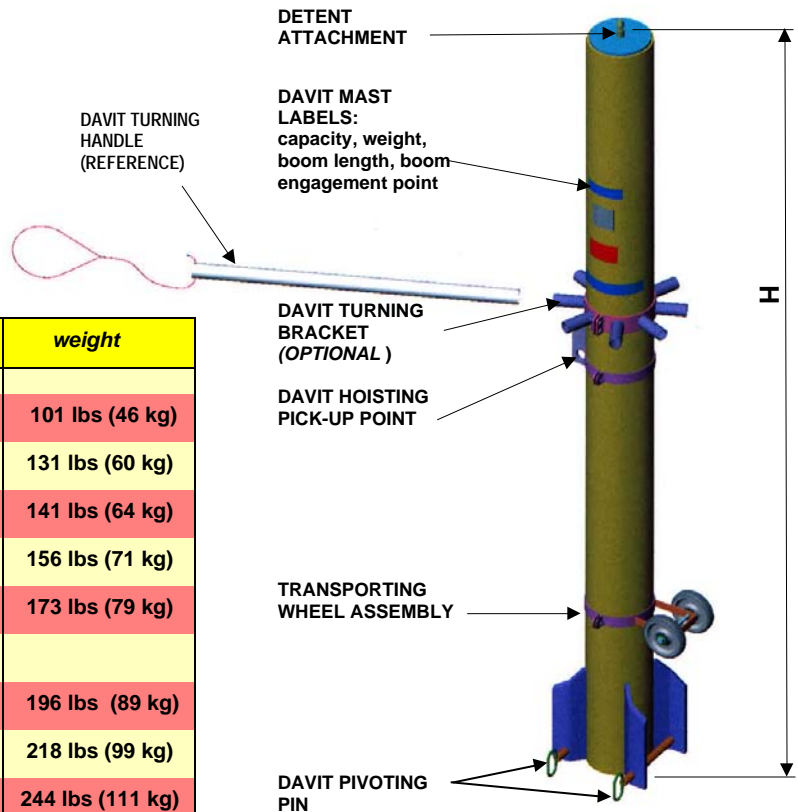

boom reach	model no.	height (H)	weight
5' to 8'-6"	DAM5062-000*	5'-3" (1.63 m)	101 lbs (46 kg)
	DAM5100-000	8'-4" (2.54 m)	131 lbs (60 kg)
	DAM5112-000	9'-4" (2.87 m)	141 lbs (64 kg)
	DAM5130-000	10'-10" (3.33 m)	156 lbs (71 kg)
	DAM5150-000	12'-6" (3.81 m)	173 lbs (79 kg)
9' to 12'-6"	DAM8112-000	9'-4" (2.87 m)	196 lbs (89 kg)
	DAM8130-000	10'-10" (3.33 m)	218 lbs (99 kg)
	DAM8150-000	12'-6" (3.81 m)	244 lbs (111 kg)

* Transporting Wheels Optional

plan

davit booms

The **davit boom** separates from the mast for ease of transportation. The boom rotates smoothly around the mast on a unique roller collar, while a captive trolley rolls within the custom extrusion, to allow optimum positioning of the work platform it suspends. See *General Information T4751 page 2*.

All booms have a rated capacity of 1150 lbs. or 525kg.

materials:

Type 6061 T-6 aluminum, G40.21-44W galvanized steel Fy = 44 KSI, A307 zinc plated steel, A307 zinc plated or A325 galvanized steel fasteners, bronze bushings.



ALUMINUM EXTRUSION SECTION
series DAB

DAVIT BOOMS series DAB

Model #	Boom Reach R	Weight
DAB050-000	5'-0" (1.53 m)	79 lbs (36 kg)
DAB056-000	5'-6" (1.68 m)	81 lbs (37 kg)
DAB060-000	6'-0" (1.83 m)	84 lbs (38 kg)
DAB066-000	6'-6" (1.98 m)	86 lbs (39 kg)
DAB070-000	7'-0" (2.18 m)	96 lbs (44 kg)
DAB076-000	7'-6" (2.29 m)	99 lbs (45 kg)
DAB080-000	8'-0" (2.44 m)	101 lbs (46 kg)
DAB086-000	8'-6" (2.59 m)	103 lbs (47 kg)
DAB090-000	9'-0" (2.74 m)	107 lbs (49 kg)
DAB096-000	9'-6" (2.89 m)	109 lbs (50 kg)
DAB100-000	10'-0" (3.05 m)	111 lbs (51 kg)
DAB106-000	10'-6" (3.20 m)	113 lbs (52 kg)
DAB110-000	11'-0" (3.35 m)	115 lbs (53 kg)
DAB116-000	11'-6" (3.50 m)	117 lbs (54 kg)
DAB120-000	12'-0" (3.66 m)	119 lbs (55 kg)
DAB126-000	12'-6" (3.81 m)	121 lbs (56 kg)

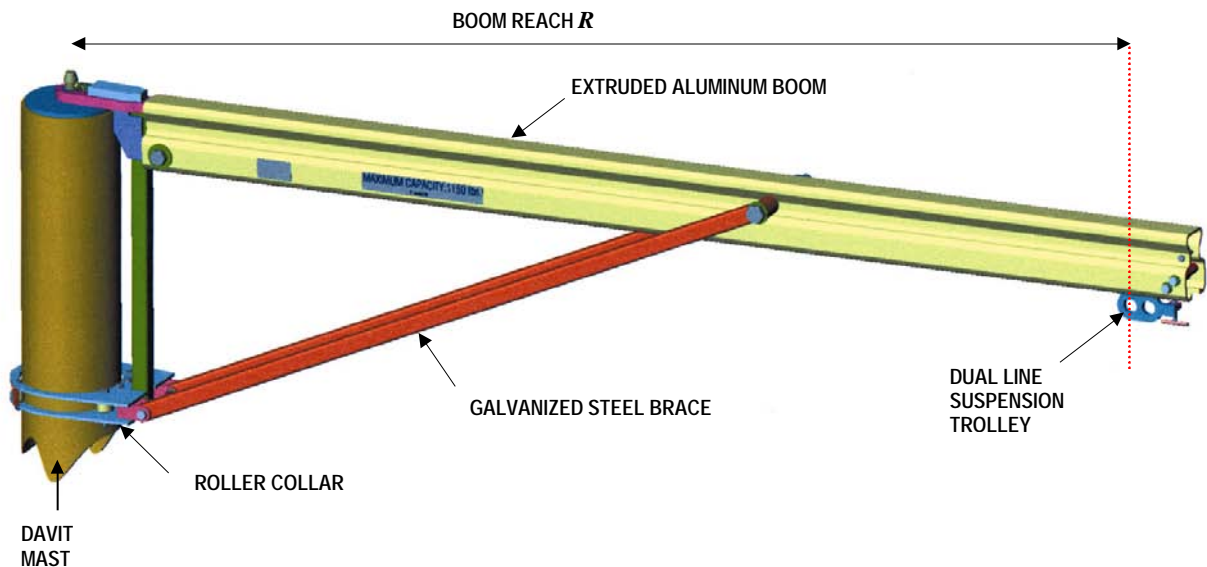

lifting kits

Lifting kits are standard davit system accessories and used with larger davit arms. They are comprised of: a *davit lifting bracket*, a *manual lifting hoist*, and a length of *wire rope*, complete with connection points at each end.

Usage

The **davit lifting bracket** is installed over the davit base, and secured with a captive pin. The davit arm mounting holes are aligned with the davit base and secured.

A **manual lifting hoist**, complete with **wire rope**, is attached between the **davit lifting bracket** and the **davit hoisting pick-up point**. The davit arm can now be easily erected using the hoist.

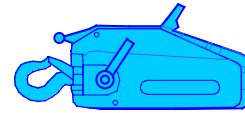

TIRFOR TU-17 MANUAL LIFTING HOIST

DAVIT LIFTING BRACKET – DLI126-000

model no.	maximum davit mast height	weight
DLI126-000	10' - 10" (3.33 m)	40 lbs (18kg)

DAVIT LIFTING BRACKET

